

What is Solar Energy?

Solar Energy originates with the thermonuclear fusion reactions occurring in the sun.

The spectrum of solar light at the Earth's surface is mostly spread across the visible and near infrared ranges with a small part in the ultraviolet region.

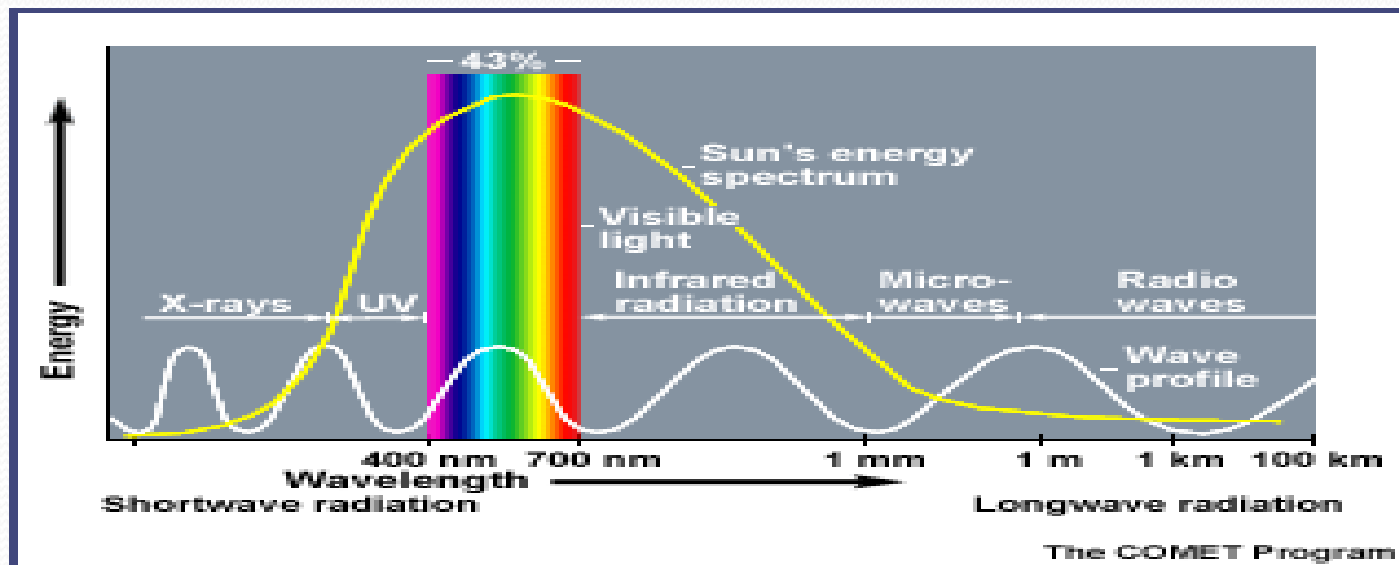

How much solar energy?

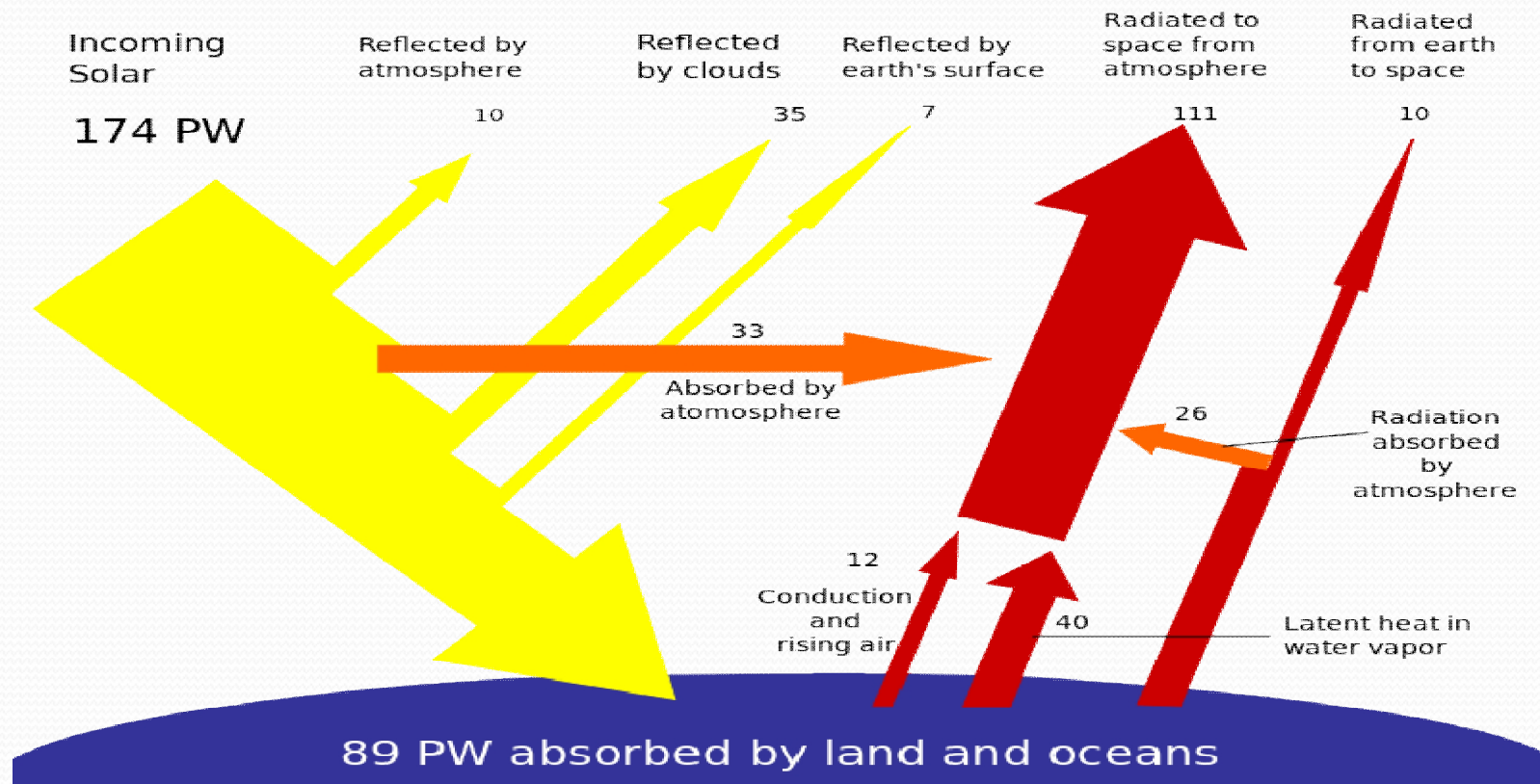

- About half the incoming solar energy reaches the Earth's surface.

Solar Map of India

About 5,000 trillion kWh per year energy is incident over India's land area with most parts receiving 4-7 kWh per square meter per day.

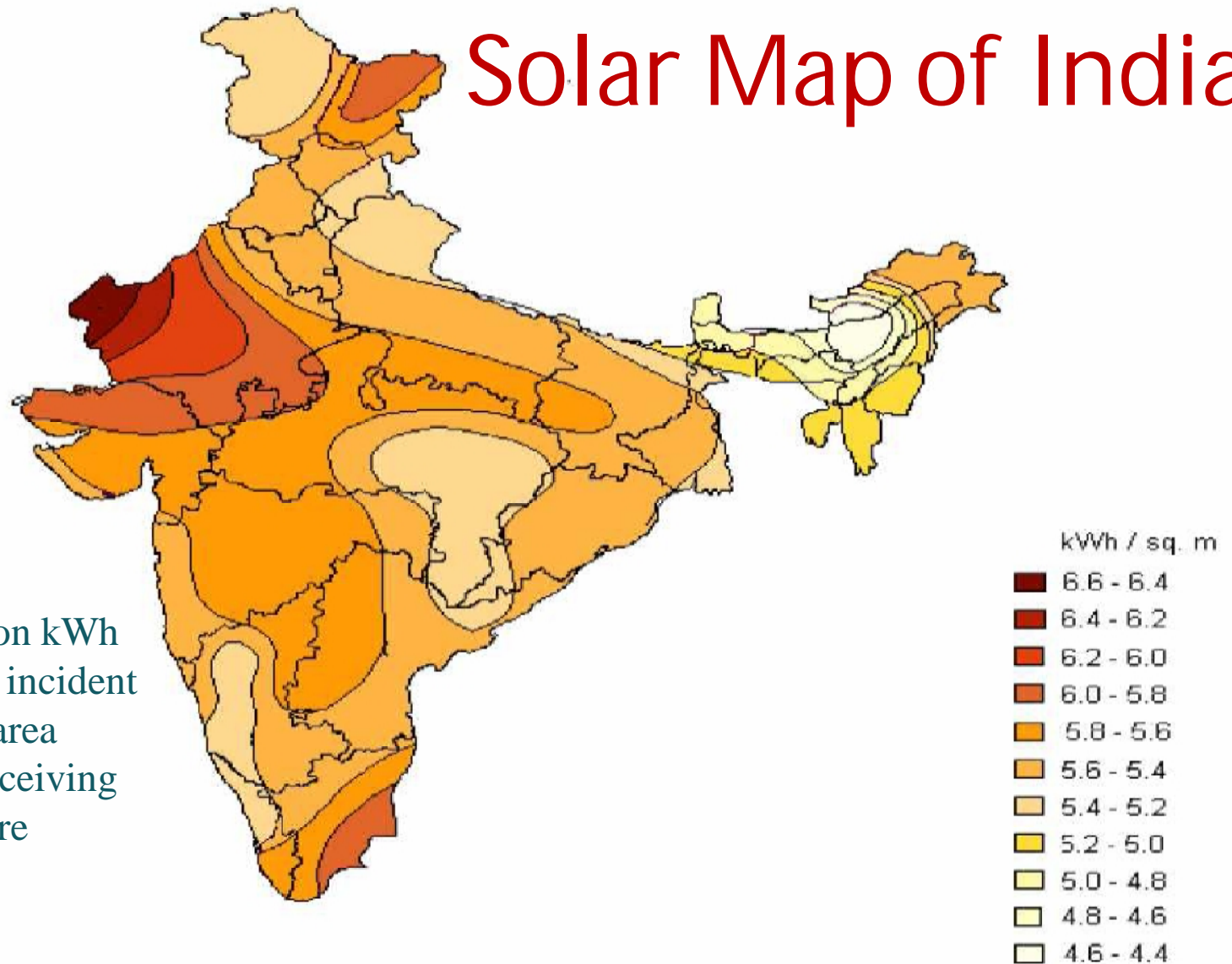

Figure 1 Solar radiation on India

Source: TERI



Solar Energy as a Resource

Solar Energy is increasingly being used as a resource in the following areas:

- Architecture and Urban Planning
- Agriculture and Horticulture
- Heating, Cooling and Ventilation
- Cooking
- Fuel Production
- **Electricity Generation**

Producing Electricity using Solar Energy

Solar Energy can be used to generate electricity in 2 ways:

- **Thermal Solar Energy:**

Using solar energy for heating fluids which can be used as a heat source or to run turbines to generate electricity.



- **Photovoltaic Solar Energy:**

Using solar energy for the direct generation of electricity using photovoltaic phenomenon.

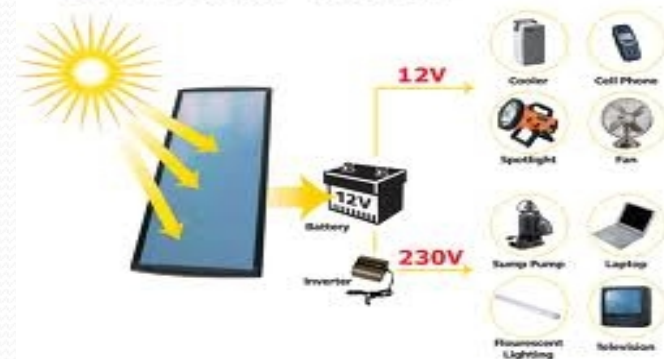

Photovoltaic Electricity

- Photovoltaic comes from the words *photo*, meaning *light*, and *volt*, a measurement of electricity.
- Photovoltaic Electricity is obtained by using photovoltaic system.
- A basic photovoltaic system consists of four components: Solar Panel, Battery, Regulator and the load.

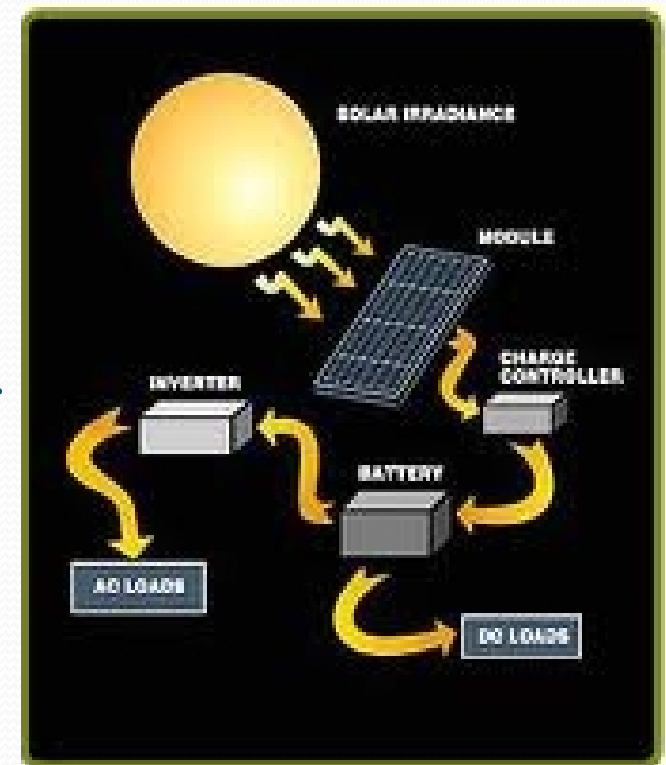

Solar Panel

- Solar Panel is an indispensable component of this system.
- Solar Panel is responsible to collect solar radiations and transform it into electrical energy.
- Solar Panel is an array of several solar cells (Photovoltaic cells).

The arrays can be formed by connecting them in parallel or series connection depending upon the energy required.



Solar Panel Manufacturing Technologies

- The most common solar technology is crystalline Si. Its two types are: Mono- Si and Poly- Si.
- **Mono-Si:** Crystal Lattice of entire Sample is continuous.
- **Poly-Si:** Composed of many crystallites of varying size and orientation.

Crystalline

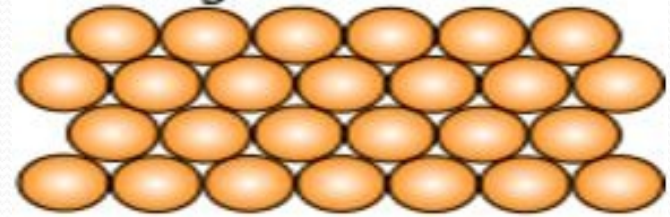

Polycrystalline

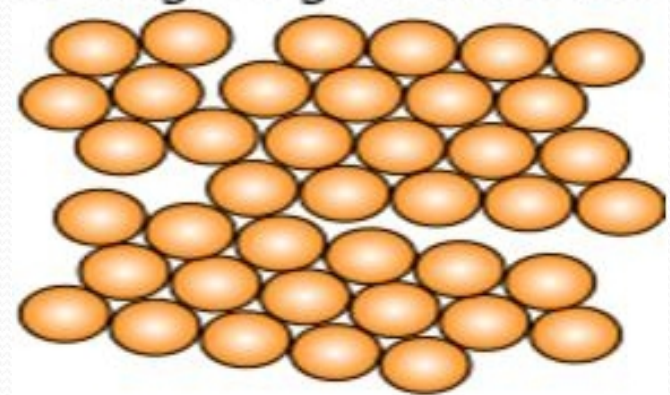

Solar Panel Manufacturing Technologies

Mono-Si Solar Panels:

- Mono-Si is manufactured by Czochralski Process.

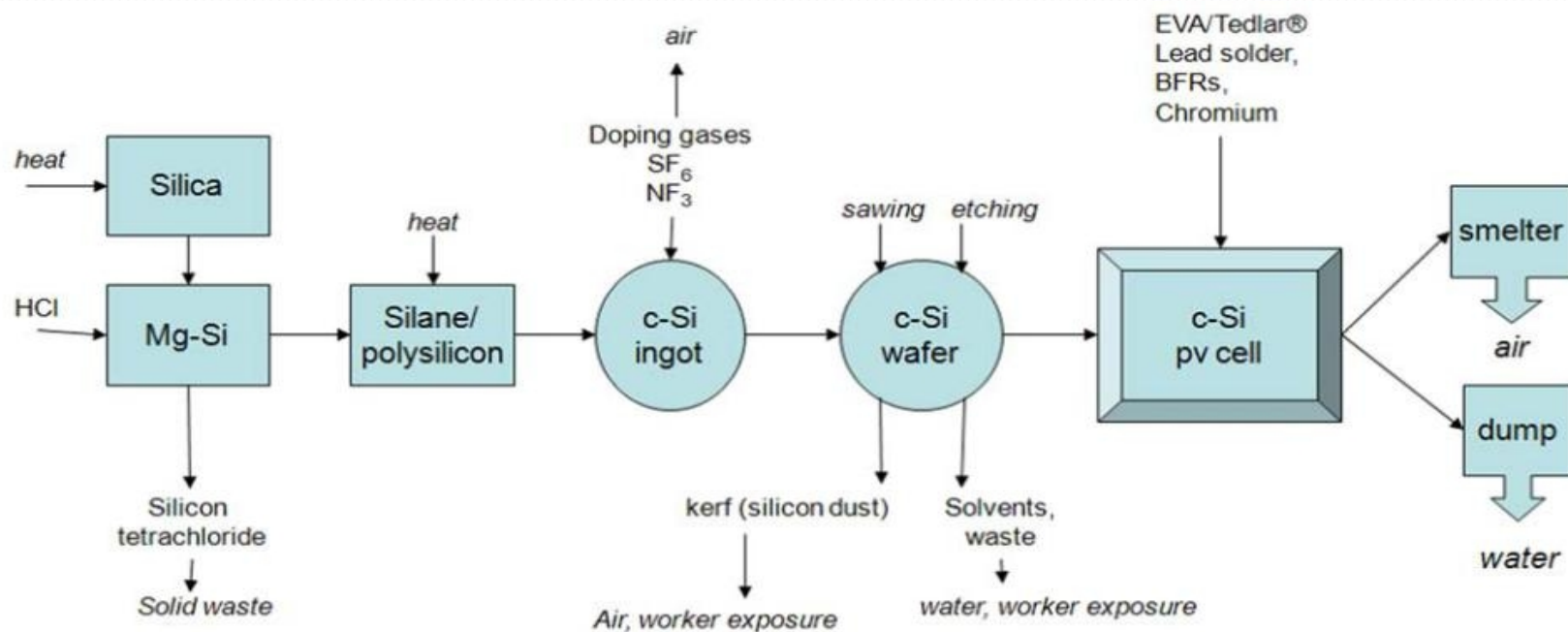

Solar Panel Manufacturing Technologies

- Since they are cut from single crystal, they give the module a uniform appearance.

Advantages:

- Highest efficient module till now with efficiency between 13 to 21%.
- Commonly available in the market.
- Greater heat resistance.
- Acquire small area where ever placed.

Disadvantages:

- More expensive to produce.
- High amount of Silicon.
- High embodied energy (total energy required to produce).



Si boule for the production of wafers.

Solar Panel Manufacturing Technologies

Poly-Si Solar Panels:

- Polycrystalline (or multicrystalline) modules are composed of a number of different crystals, fused together to make a single cell.
- Poly-Si solar panels have a non-uniform texture due to visible crystal grain present due to manufacturing process.

Advantages:

- Good efficiency between 14 to 16%.
- Cost effective manufacture.
- Commonly Available in the market.



Visible crystal grain in poly-Si

Solar Panel Manufacturing Technologies

Disadvantages:

- Not as efficient as Mono-Si.
- Large amount of Si.
- High Embodied Energy.

Visible difference between Mono-Si and Poly-Si Panels:

Mono-Si solar cells are of dark color and the corners of the cells are usually missing whereas poly-Si panels are of dark or light blue color. The difference between the structure is only due to their manufacturing process.

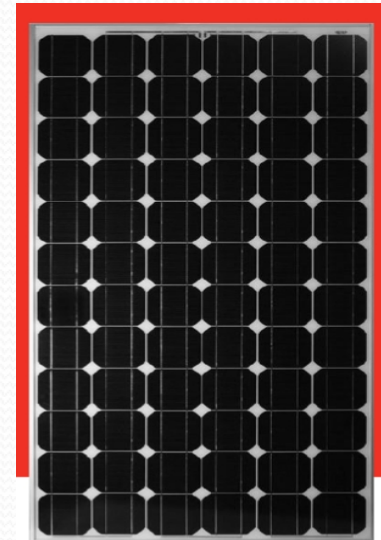

Mono-Si Panel



Poly-Si Panel

Solar Panel Manufacturing Technologies

Thin Film Solar Panels:

- Made by depositing one or more thin layers (thin film) of photovoltaic material on a substrate.
- Thin Film technology depend upon the type of material used to dope the substrate.
- Cadmium telluride (CdTe), copper indium gallium selenide (CIGS) and amorphous silicon (A-Si) are three thin-film technologies often used as outdoor photovoltaic solar power production.



Solar Panel Manufacturing Technologies

Amorphous-Si Panels:

- Non-crystalline allotrope of Si with no definite arrangement of atoms.

Advantages:

- Partially shade tolerant
- More effective in hotter climate
- Uses less silicon - low embodied energy
- No aluminum frame - low embodied energy

Disadvantages:

- Less efficient with efficiency between 6 to 12% .
- Less popular - harder to replace.
- Takes up more space for same output .
- New technology - less proven reliability.

Amorphous

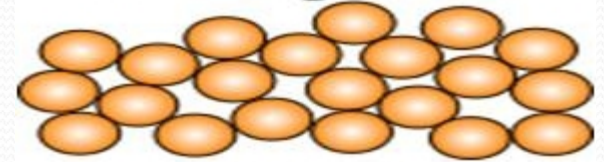

Comparison of Si on the basis of crystallinity

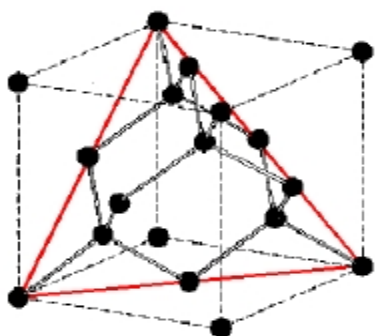

Unit cell of Si
a=0.5431 nm

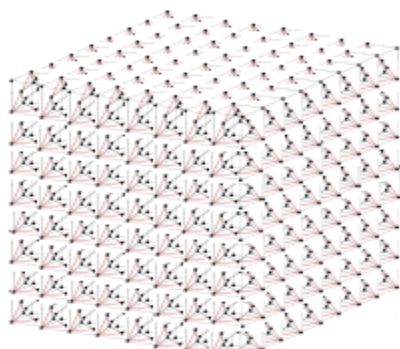

Single Crystal Si
(completely ordered)

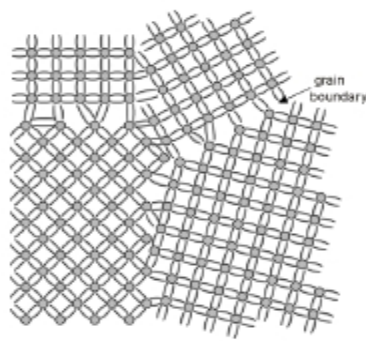

Multicrystalline or
poly Si (grains of
different orientations)

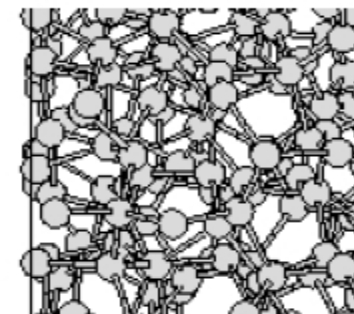

a-Si: H
(very short range order
in <1 nm regime)

	Symbol	Grain Size	Mobility (cm² V/sec)	E_g (eV)	Common Growth Techniques
Single crystal	sc-Si	Completely ordered	~10 ³	1.1	Czochralski (CZ) or float zone (FZ)
Multicrystalline Polycrystalline	mc-Si pc-Si	μm-mm	Mid 10-10 ³	1.1	Cast, ribbon, Chemical-vapor deposition (CVD)
Microcrystalline nanocrystalline	μc-Si nc-Si	<1μm <5 nm	Mid 10	1.1 1.1-1.7	CVD, sputtering
Amorphous	a-Si/ a-Si:H	Very short range order <1 nm	1-10	1.7-1.9	CVD

Behaves more like direct gap

Comparison of Mono-Si, Poly-Si and Thin film Panels

Mono-Si Panels	Poly-Si Panels	Thin Film Panels
1. Most efficient with max. efficiency of 21%.	1. Less efficient with efficiency of 16% (max.)	1. Least efficient with max. efficiency of 12%.
2. Manufactured from single Si crystal.	2. Manufactured by fusing different crystals of Si.	2. Manufactured by depositing 1 or more layers of PV material on substrate.
3. Performance best at standard temperature.	3. Performance best at moderately high temperature.	3. Performance best at high temperatures.
4. Requires least area for a given power.	4. Requires less area for a given power.	4. Requires large area for a given power.
5. Large amount of Si hence, high embodied energy.	5. Large amount of Si hence, high Embodied energy.	4. Low amount of Si used hence, low embodied energy.
6. Performance degrades in low-sunlight conditions.	6. Performance degrades in low-sunlight conditions.	5. Performance less affected by low-sunlight conditions.
7. Cost/watt: 1.589 USD	7. 1.418 USD	7. 0.67 USD
8. Largest Manufacturer: Sunpower (USA)	8. Suntech (China)	8. First Solar (USA)

What is a Solar Cell?

Solar Cells

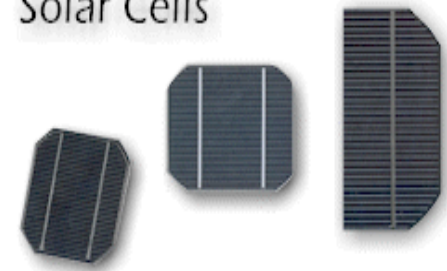

- A structure that converts solar energy directly to DC electric energy.
- It supplies a voltage and a current to a resistive load (light, battery, motor).

$$\text{Power} = \text{Current} \times \text{Voltage} = \text{Current}^2 \times R = \text{Voltage}^2 / R$$

- It is like a battery because it supplies DC power.
- It is not like a battery because the voltage supplied by the cell changes with changes in the resistance of the load.

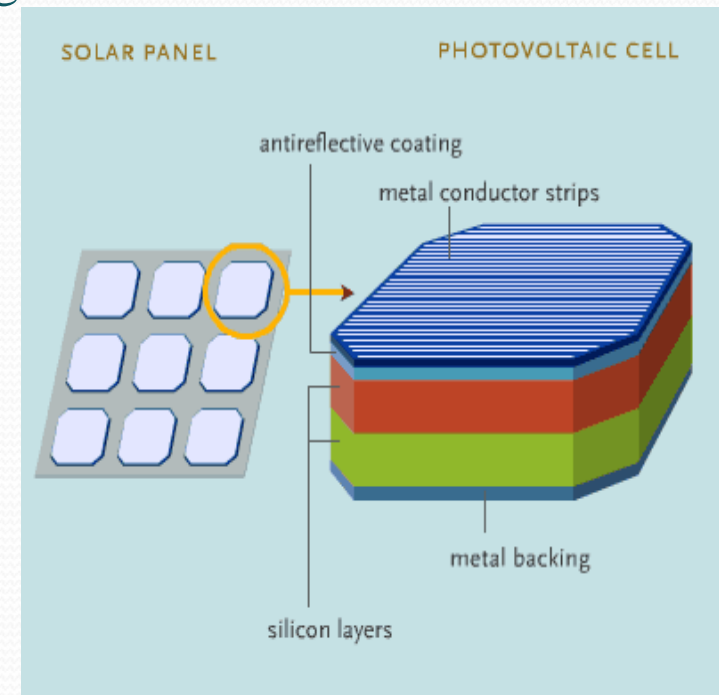

Silicon Solar cell

Principle p-n Junction Diode:

The operation of a photovoltaic (PV) cell requires 3 basic attributes:

The absorption of light, generating either electron-hole pairs or excitons.

The separation of charge carriers of opposite types.

The separate extraction of those carriers to an external circuit.

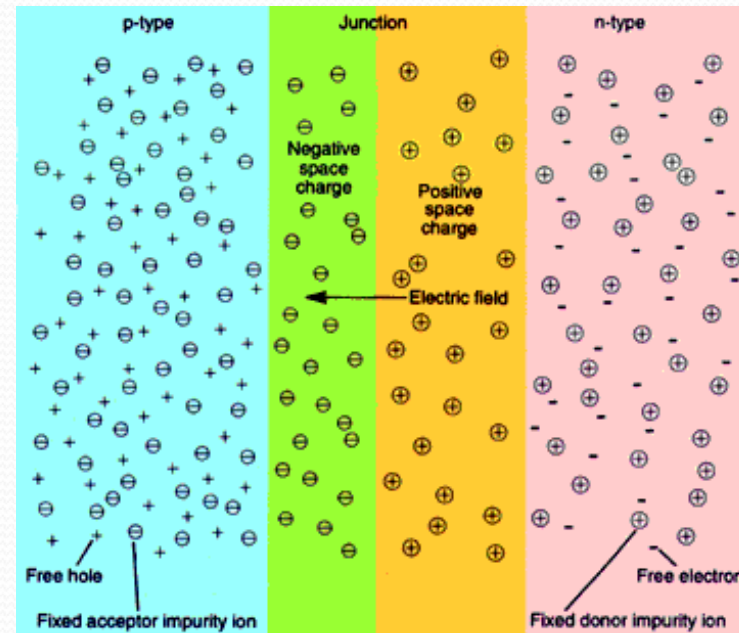
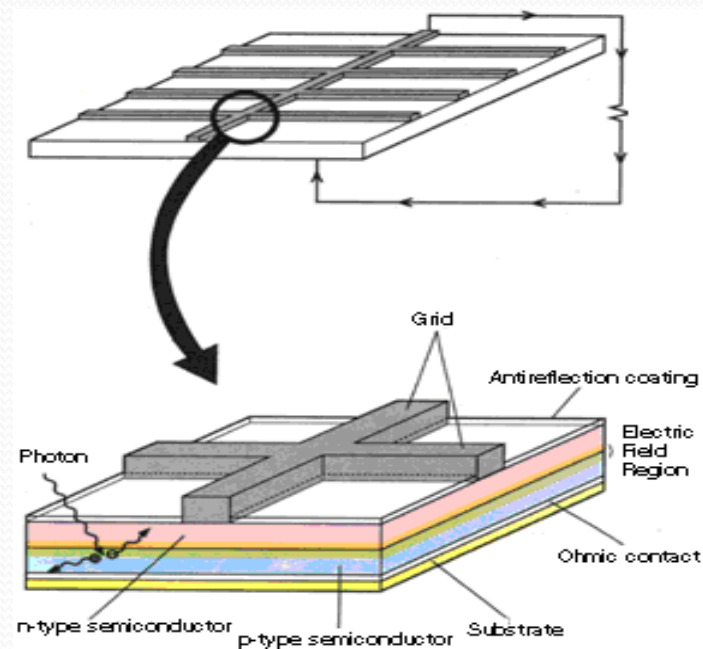

Ref. Soft Condensed Matter physics group in
univ. of Queensland

Silicon Solar cell Working

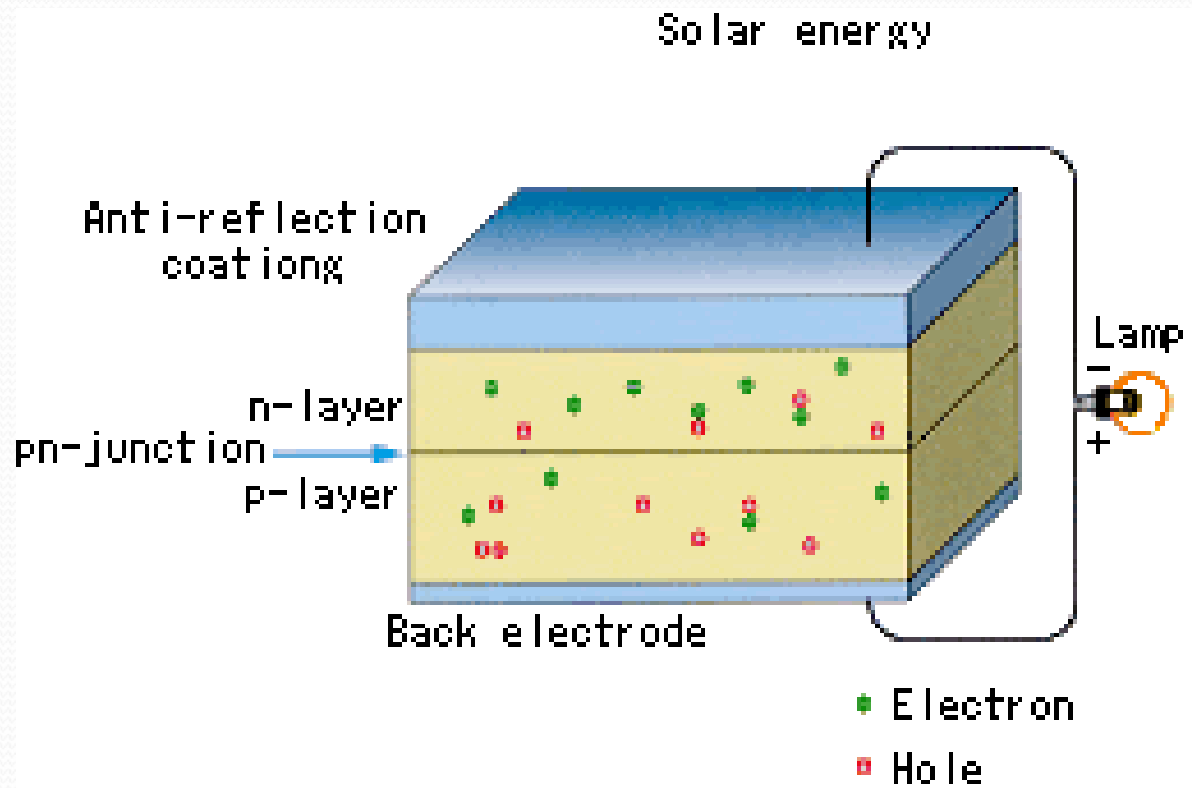

How a panel is created?

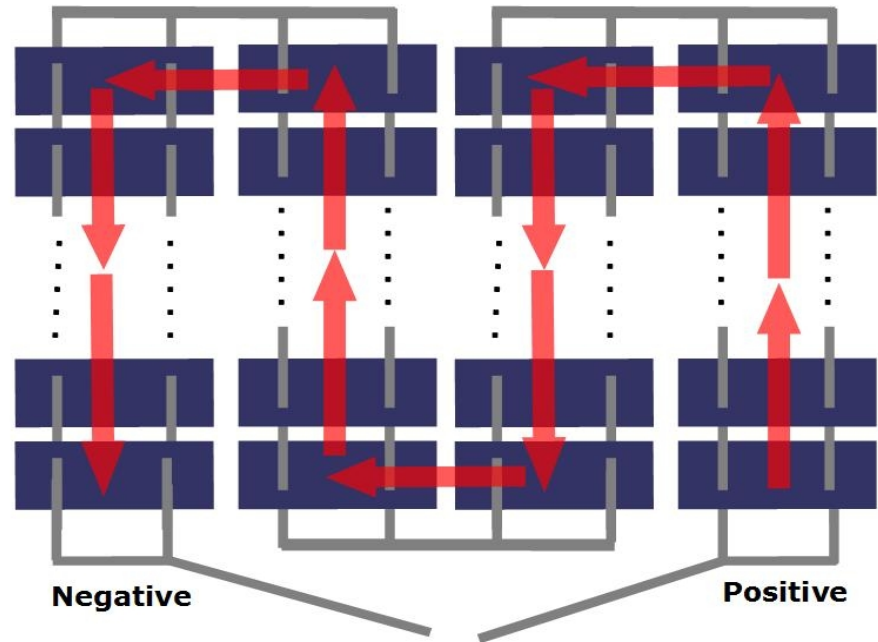
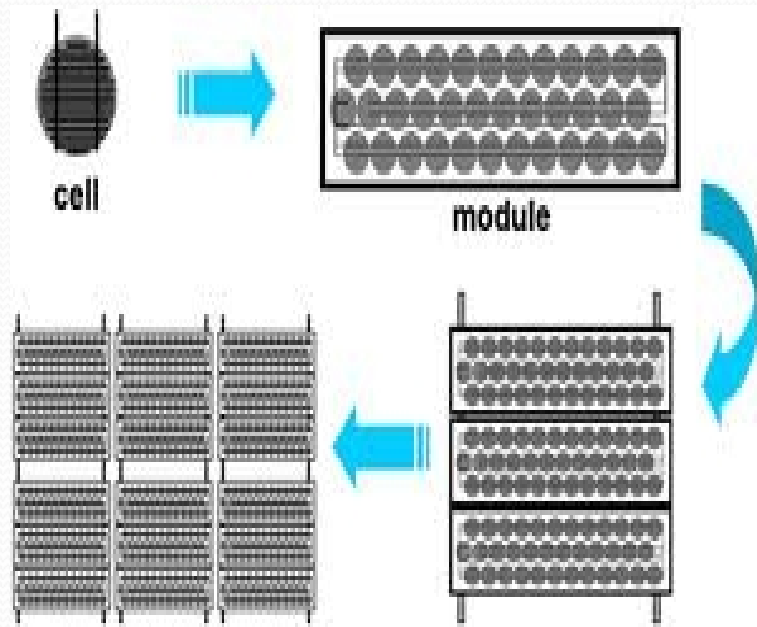

Panel wiring diagram connecting cells

- An individual PV cell typically produces 0.6 watts and are joined in an array to produce the required power.

Blocking Diodes

- When the sun shines, as long as the voltage produced by the panels is greater than that of the battery, charging will take place.
- However, in the dark, when no voltage is being produced by the panels, the voltage of the battery would cause a current to flow in the opposite direction through the panels, which can lead to the discharging of battery. Hence a blocking diode is used in series with the panels and battery in reverse biasing.

- Normal p-n junction diodes can be used as blocking diodes.
- To select a blocking diode, following parameters should be kept in mind:

The maximum current provided by the panels.

The voltage ratings of the diode.

The reverse breakdown voltage of the diode.

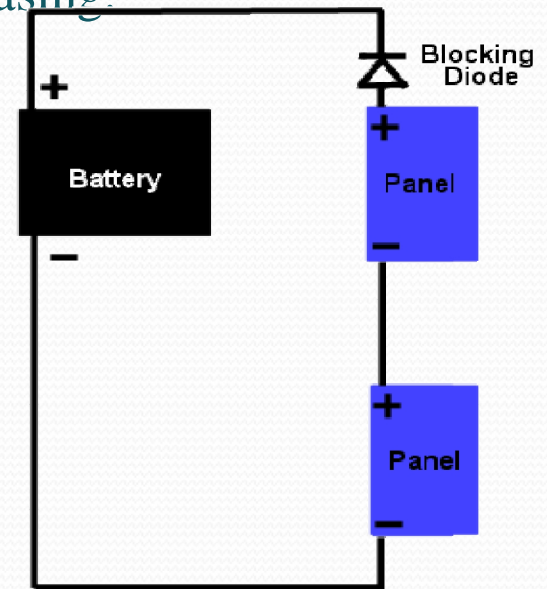

Hot-Spot and Bypass Diodes

- Hot Spot phenomenon happens when one or more cells of the panel is shaded while the others are illuminated.
- The shaded cells/panels starts behaving as a diode polarized in reverse direction and generates reverse power. The other cells generate a current that flows through the shaded cell and the load.
- Any solar cell has its own critical power dissipation P_c that must not be exceeded and depends on its cooling and material structures, its area, its maximum operating temperature and ambient temperature.
- A shaded cell may be destroyed when its reverse dissipation exceeds P_c . This is the hot spot.
- To eliminate the hot-spot phenomenon, a bypass diode is parallelly connected to the module or group of cells in reverse polarity which provides another path to the extra current.

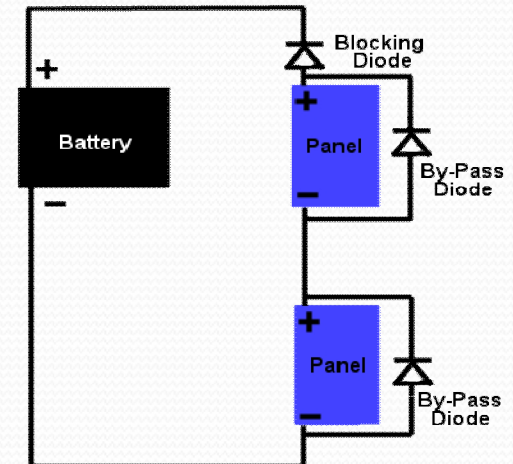
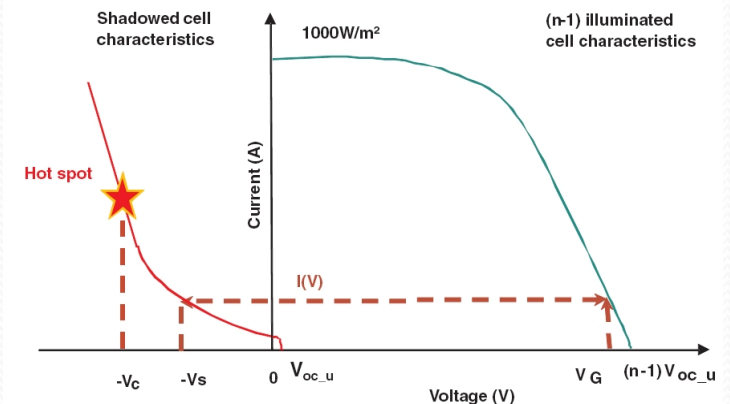

Bypass Diodes working

▪ When part of a PV module is shaded, the shaded cells will not be able to produce as much current as the unshaded cells. Since all cells are connected in series, the same amount of current must flow through every cell. The unshaded cells will force the shaded cells to pass more current through it. The only way the shaded cells can operate at a current higher than their short circuit current is to operate in a region of negative volt age i.e. to cause a net voltage loss to the system.

▪ The voltage across the shaded or low current solar cell becomes greater than the forward bias voltage of the other series cells which share the same bypass diode plus the voltage of the bypass diode thus making the diode to work in forward bias and hence allowing extra current to pass through it, preventing hot-spot.

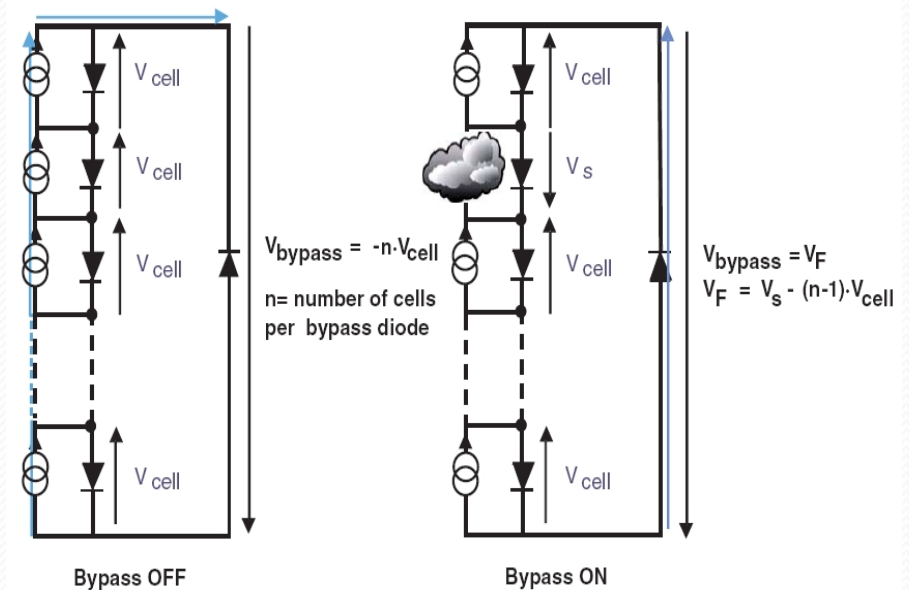

Bypass diode working phases

Bypass Diodes working

▪ For an efficient operation, there are two conditions to fulfill:

1. Bypass diode has to conduct when one cell is shadowed.
2. The shadowed cell voltage V_s must stay under its breakdown voltage (V_c).

Ideally, a bypass diode should have a forward voltage (V_F) and a leakage current (I_R) as low as possible.

▪ Two types of diodes are available as bypass diodes in solar panels and arrays:

1. p-n junction silicon diode
2. Schottky barrier diode

▪ To select a bypass diode, following parameters should be checked:

1. The forward voltage and current ratings of the diode.
2. The reverse breakdown voltage of the diode.
3. The reverse leakage current.
4. Junction Temperature Range

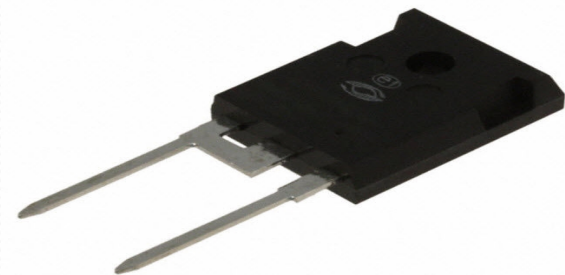
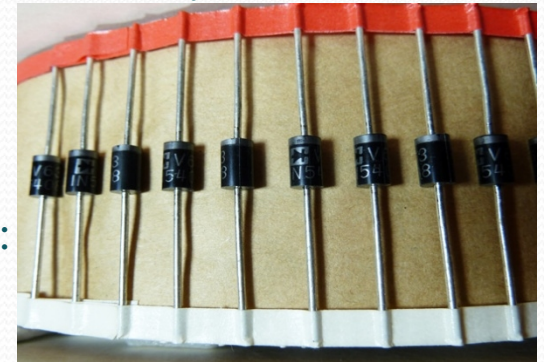

Solar Panel specifications

▪ Mechanical Specifications:

1. **Solar Cell Type:** Defines the type of module or cell used in the module.
e.g.- Mono-Si, Poly-Si or Thin Film.

Design Implication: This determines the class of conversion efficiency of the module.

2. **Cell Dimension** (in inches/mm.): Defines the size of cell used in the module.
e.g.- 125(l) × 125 mm(b) (5 inches).

Design Implication: This determines the output power of a single solar cell.

3. **Module Dimension** (in inches/mm.): Defines the size of the panel.
e.g.- 1580 (l) × 808 (b) × 35 (h) mm.

Design Implication: Determines the number of cells accommodated in the module.

Across length: $1580/125 = 12.64 \sim 12$ [least integer].

Across breadth: $808/125 = 6.4 \sim 6$.

This means number of cell be 72 (6*12).



Solar Panel specifications

▪ Mechanical Specifications:

4. Module Weight (in kgs./lbs.): Defines the weight of the module.

e.g.- 15.5 kgs. (34.1 lbs.)

Design Implication: Determines the maximum number of panels which can be installed.

5. Glazing or front Glass: Defines the type and width of the front glass used.

e.g.- 3.2 mm (0.13 inches) tempered glass.

Design Implication: Width determines the strength of the covering. The type of glass used depends upon thermal insulation requirements or strength requirement.

6. Frame: Defines the type of frame used in the module.

e.g.- Anodized aluminium alloy

Design Implication: Frame material is chosen so that it can Withstand the environmental effects such as corrosion, hard Impact, etc.

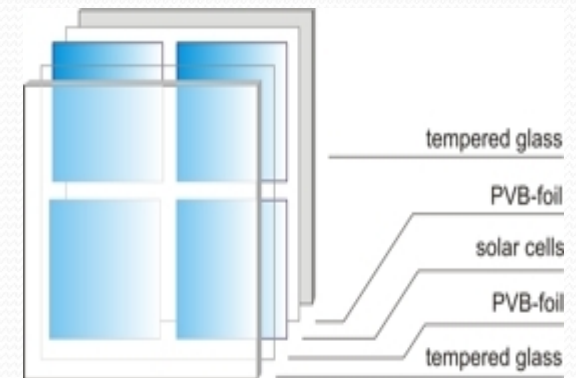

Solar Panel specifications

▪ Mechanical Specifications:

7. Output Cables: Defines the type of cables and sometimes their dimensions provided at output to connect with connector specifications.

e.g.- H+S RADOX® SMART cable 4.0 mm² of length 1000 mm (39.4 inches) with RADOX® SOLAR integrated twist locking connectors.

Design Implication: The rating of the cable is as per rating of the PV module and of optimum length generally required by the customers.

8. Junction Box: Defines the protection level of electrical casing at the back of panel. Also includes the no. of bypass diodes (if used).

e.g.- IP67 rated with 3 bypass diodes.

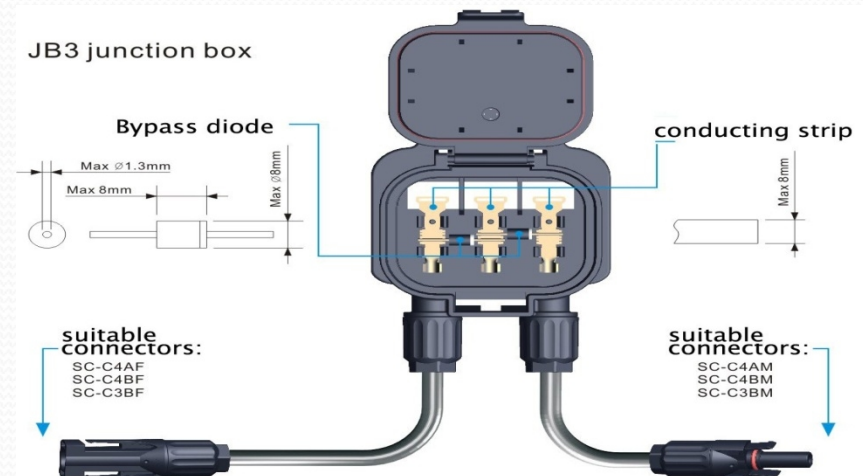

Solar Panel specifications

▪ Electrical specifications:

1. Peak Power (W): Defines the maximum power of the panel.

e.g.- P: 195 W

Design Implication:

2. Optimum operating Voltage: Defines the highest operating voltage of panel at the maximum power at STC.

e.g.- V_{mp} : 36.6V

Design Implication: Determines the number of panels required in series.

3. Optimum operating current: Defines the highest operating current of panel at the maximum power at STC.

e.g.- I_{mp} : 5.33A

Design Implication: Determines the wire gauge.

Used to calculate the voltage drops across the modules or cells.

Solar Panel specifications

▪ Electrical Specs:

4. Open Circuit Voltage: Defines the output voltage when no load is connected under STC.

e.g.- $V_{oc} : 45.4V$

Design Implication: Determines the maximum possible voltage.

Determines the maximum number of modules in series.

5. Short Circuit Current: Defines the protection level of electrical casing at the back of panel. Also includes the no. of bypass diodes (if used).

e.g.- $I_{sc} : 5.69A$

Design Implication: Determines the current rating of fuse which is to be used for protection.

Determines the conductor size.

General I-V curve

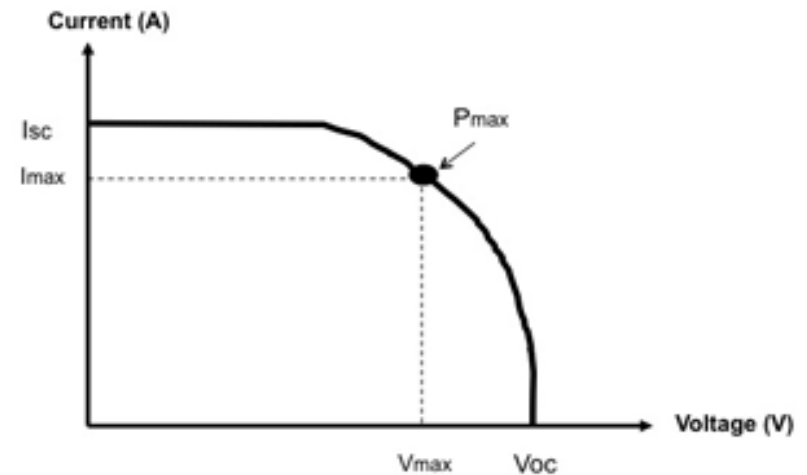

Solar Panel specifications

▪ Electrical Specifications:

6. I-V Characteristics: Defines the current and voltage variation for the panel. Also shows I-V characteristics for different irradiance.

e.g.-

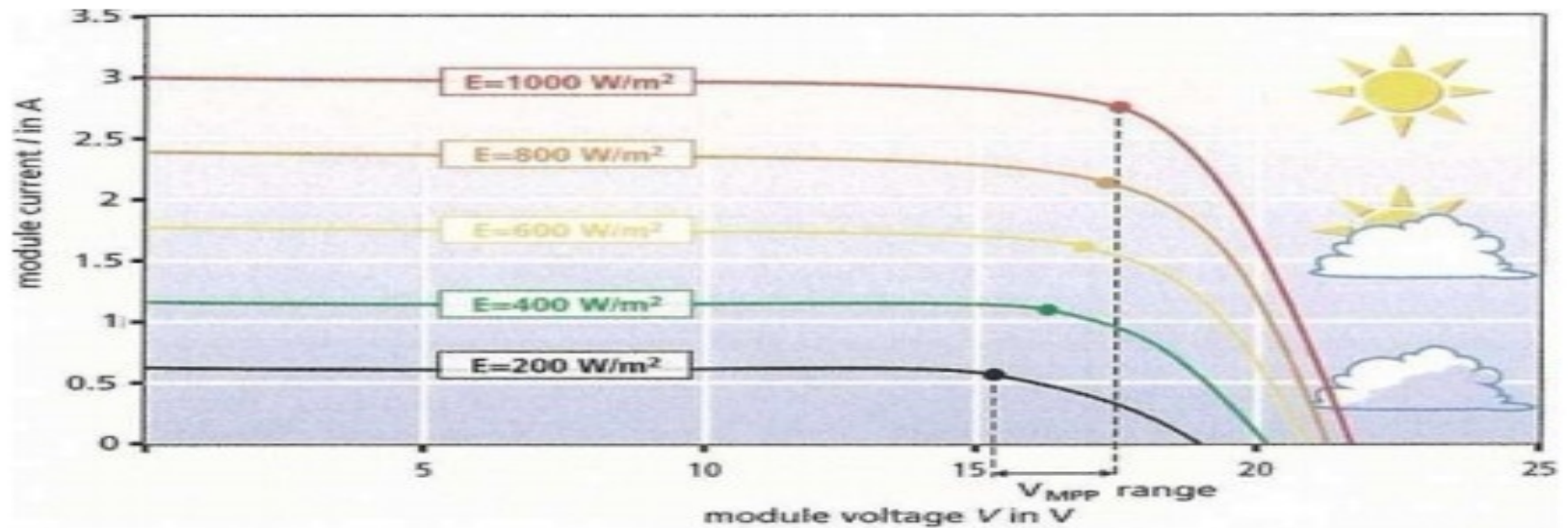

Variation in I-V characteristics with Irradiance

Design Implication: This parameter determines the module current and voltage for a particular value of irradiance.

This can be used to obtain the output voltage at the lowest irradiance for a region.

Solar Panel specifications

▪ Electrical Specifications:

7. Module Efficiency: Defines the conversion efficiency given by a given module (which is generally lesser than the single solar cell used in the module).

e.g.- 15.3%

Design Implication: This parameter helps in solving the problem of choosing a module.

8. Operating Temperature: Defines the range of temperature for which the module can function.

e.g.- -40°C to 85°C

Design Implication: Determines the temperature range for the environment in which the panel can be kept.

9. Max. Series Fuse Rating: Defines the max. current which can be handled by the module without damage.

e.g.- 15 A

Design Implication: This defines the rating of fuse to be used with the module.

Solar Panel specifications

▪ Electrical Specifications:

10. Power Tolerance: Defines the range of power deviation from its stated power ratings due to change in its operating condition. It is defined in %.

e.g.- 0/+5 %

Design Implication: This parameter determines the upper limit for power of a module.

11. Parameters defined under NOCT: These parameters are same as defined under STC conditions with different values.

Difference between STC and NOCT:

STC (Standard Test Conditions):

Irradiance 1000 W/m², Module temperature 25 °C, Air Mass=1.5

NOCT(Nominal Operating Cell Temperature):

Irradiance 800 W/m², Ambient temperature 20 °C, Wind speed 1 m/s

Solar Panel specifications

▪ Electrical Specifications:

12. Temperature Coefficients: These coefficients are defined to show the possible rate of change of values under varying module temperature and irradiance.

Design Implication: These parameters can be used to calculate the power, current and voltage of the module.

Temperature Coefficient of Voc can also be used to determine the maximum panel voltage at the lowest expected temperature.

▪ Packing Configuration:

Pieces per pallet: Number of modules per box.

Pallet per container: Number of boxes per container.

Pieces per container: Number of modules per container.

e.g.- Pieces per pallet (26) X Pallets per container (12)= Pieces per container (312)

Nominal Operating Cell Temperature (NOCT)	45±2°C
Temperature Coefficient of Pmax	-0.45 %/°C
Temperature Coefficient of Voc	-0.34 %/°C
Temperature Coefficient of Isc	0.050 %/°C

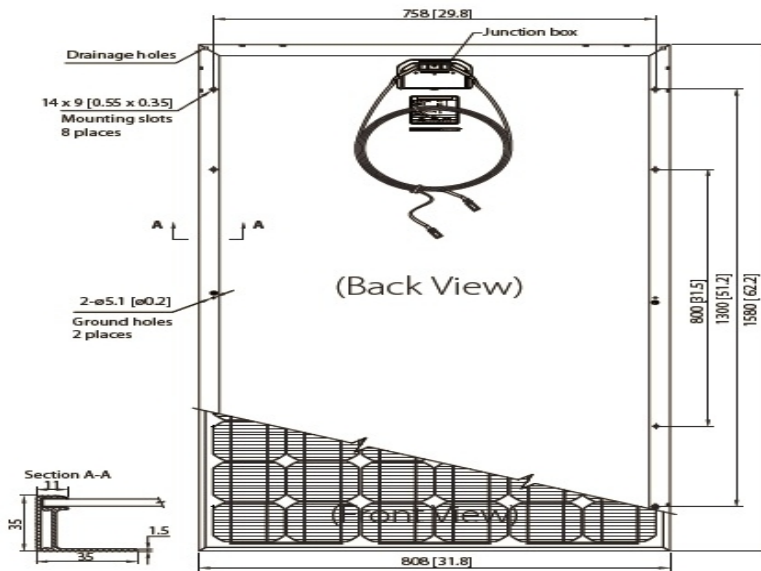

Note: mm [inch]

Current-Voltage & Power-Voltage Curve (190S-24)

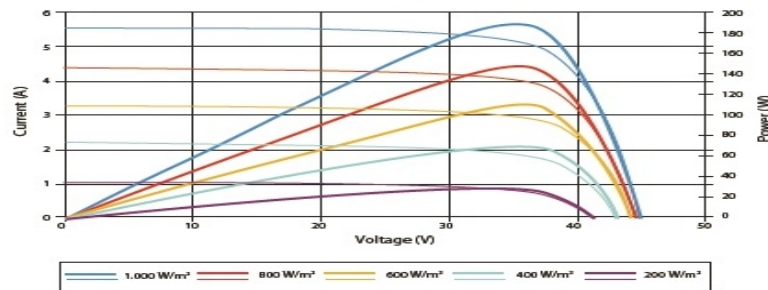

Temperature Characteristics

Nominal Operating Cell Temperature (NOCT)	45±2°C
Temperature Coefficient of Pmax	-0.48 %/°C
Temperature Coefficient of Voc	-0.34 %/°C
Temperature Coefficient of Isc	0.037 %/°C

Dealer information box	
------------------------	--

Electrical Characteristics

STC	STP195S-24/Ad+	STP190S-24/Ad+
Optimum Operating Voltage (Vmp)	36.6 V	36.5 V
Optimum Operating Current (Imp)	5.33 A	5.20 A
Open - Circuit Voltage (Voc)	45.4 V	45.2 V
Short - Circuit Current (Isc)	5.69 A	5.62 A
Maximum Power at STC (Pmax)	195 W	190 W
Module Efficiency	15.3%	14.9%
Operating Temperature	-40 °C to +85 °C	-40°C to +85°C
Maximum System Voltage	1000 V DC	1000 V DC
Maximum Series Fuse Rating	15 A	15 A
Power Tolerance	0/+5 W	0/+5 W

STC: Irradiance 1000 W/m², module temperature 25 °C, AM=1.5

NOCT	STP195S-24/Ad+	STP190S-24/Ad+
Maximum Power (W)	142 W	139 W
Maximum Power Voltage (V)	33.2 V	33.1 V
Maximum Power Current (A)	4.27 A	4.19 A
Open Circuit Voltage (Voc)	41.8 V	41.3 V
Short Circuit Current (Isc)	4.61 A	4.56 A
Efficiency Reduction (from 1000 W/m ² to 200 W/m ²)	<4.5%	<4.5%

NOCT: Irradiance 800 W/m², ambient temperature 20 °C, wind speed 1 m/s

Mechanical Characteristics

Solar Cell	Monocrystalline 125 × 125 mm (5 inches)
No. of Cells	72 (6 × 12)
Dimensions	1580 × 808 × 35mm (62.2 × 31.8 × 1.4 inches)
Weight	15.5 kgs (34.1 lbs.)
Front Glass	3.2 mm (0.13 inches) tempered glass
Frame	Anodized aluminium alloy
Junction Box	IP67 rated
Output Cables	H+S RADOX® SMART cable 4.0 mm ² (0.006 inches ²), symmetrical lengths (-) 1000 mm (39.4 inches) and (+) 1000 mm (39.4 inches), RADOX® SOLAR integrated twist locking connectors

Packing Configuration

Container	20' GP	40' GP
Pieces per pallet	26	26
Pallets per container	12	28
Pieces per container	312	728

Comparison between Suntech, Trina and Sanyo 190W Monocrystalline modules

Parameters at STC	Sanyo (HIP-190DA3)	Suntech (STP190S-24/Ad+)	Trina (TSM-190DC01A)
Optimum Operating Voltage (Vmp)	55.3 V	36.5 V	36.8 V
Optimum Operating Current (Imp)	3.44 A	5.20 A	5.18 A
Open - Circuit Voltage (Voc)	68.1 V	45.2 V	45.1 V
Short - Circuit Current (Isc)	3.7 A	5.62 A	5.52 A
Maximum Power at STC (Pmax)	190 W	190 W	190 W
Module Efficiency	15.7%	14.9%	14.9%
Maximum Series Fuse Rating	15 A	15 A	10 A
Maximum System Voltage	600 VDC	1000 V DC	1000VDC
Power Tolerance	+10/-0%	0/+5 %	0/+3
Temperature Coefficient of Pmax	-0.34% / °C	-0.48 %/°C	- 0.45%/°C
Temperature Coefficient of Voc	-0.191 V / °C	-0.34 %/°C	- 0.35%/°C
Temperature Coefficient of Isc	1.68 mA / °C	0.037 %/°C	0.05%/°C
Module Dimension	53.2 x 35.35 x 2.36 in. (1351 x 898 x 60 mm)	62.2 × 31.8 × 1.4 inches (1580 × 808 × 35mm)	62.24 x 31.85 x 1.57in. (1581 x 809 x 40mm)
Warranty :	90% power output 20 Years 80% power output 20 Years	12 years 25 years	10 years 25 years
Cost:	\$570.00	\$285.00	\$459.00



Comparison between Mono-, Poly- and Amorphous Si Solar Panels (5 W)

Parameters at STC	Monocrystalline (S.C. Origin)	Polycrystalline (Moserbaer)	Thin Film (a-si) (China Solar)
Optimum Operating Current (Imp)	0.285A	0.29A	0.278 A
Short - Circuit Current (Isc)	0.315A	0.35A	0.401 A
Module Efficiency	16.2%	14%	Not Available
Temperature Coefficient of Voc	-0.397% /°K	-0.344 %/°K	-(0.34±0.04)%/°C
Maximum System Voltage	1000 VDC	600VDC	600 VDC
Warranty:	90% power output 85% power output	10 years 25 years	10 years 15 years

How to choose a solar panel?

Critical parameters to be considered for solar panel evaluation:

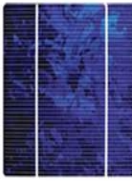
1. Selecting the right technology : The selection of solar panel technology generally depends on space available for installation and the overall cost of the system.
3. Selecting the right manufacturer for better warranty.
4. Check operating specifications beyond STC ratings
5. Negative Tolerance can lead to a lower system performance and reduced capacity
6. Solar Panel efficiency under different conditions and over time.

Solar cell technology	Characteristics
 Monocrystalline	Structure: Formed from single crystal of silicon Typical Module Efficiency: 13% - 20% Typical Module Price /Wp: Rs.75 – Rs.100
 Polycrystalline	Structure: Formed from multiple crystals of silicon Typical Module Efficiency: 14% - 16% Typical Module Price/Wp: Rs.50 – Rs.75
 Thin film	Structure: Formed from amorphous silicon Typical Module Efficiency: 6% - 12% Typical Module Price/Wp: Rs.40 – Rs.55

How to design a PV Off-grid system?

1. **Collect some data** viz. Latitude of the location, and solar irradiance (one for every month).

2. **Calculation of total solar energy.**

3. **Estimate the required electrical energy on a monthly/weekly basis (in kwh):**

Required Energy= Equipment Wattage X Usage Time.

4. **Calculate the system size using the data from ‘worst month’** which can be as follows:

a) The current requirement will decide the number of panels required.

b) The days of autonomy decides the storage capacity of the system i.e. the number of batteries required.

